

ZCT100AL-485-BUS 1-axis Inclinometer sensor

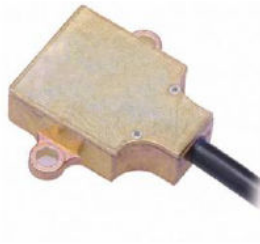

I. General Description:

ZCT100AL-485-BUS is 1-axis inclinometer sensor designed and produced by ZC Tech with a measuring range of 0~360°, output of RS485 BUS.

II. Features:

- Small size, light weight
- Entirely industrial device
- Stable and reliable performance
- Shockproof
- High cost performance,easy to integration
- Wide supply

III. Applications:

- Aerial lifts, medical devices
- Security control, monitoring, alarm system
- Boom angle measurement

IV. Technical Specification: (room environment (25°C))

	Parameter	Test condition	Min.	Typ.	Max.	Unit
Operating parameters	Power supply		7		15	V (DC)
	Quiescent current	No load		17	25	mA
	Operating temp range		-40		+85	°C
Performance parameters	Total range	1-axis	0		360	°
	Resolution ⁽¹⁾			0.1		°
	Accuracy	RMS		≤0.5		°
	Zero temp drift	-40~+85°C		±0.03		°/°C
Other parameters	Size	Housing		41*46*15.2		mm
	Standard cable			0.3		m

Remark 1: resolution is the smallest angular increment at which a detectable change in output can be measured.

V. Digital output of the angle

1. RS485 serial port setting:

Baud rate: 9600bps, one start byte, eight data bytes, one stop byte, and no parity byte.

2. Output format of the angle:

There is nine bytes of a group output data.

Byte1: 0x2A

Byte2: 0x2B/0x2D

Byte3: thousands of the angle (ASCII)

Byte4: hundreds of the angle (ASCII)

Byte5: tens of the angle (ASCII)

Byte6: units of the angle (ASCII)

Byte7: 0x2E

Byte8: tenths of the angle (ASCII)

Byte9: 0x0F

Ex: the current angle value is +3.6 deg, the display of the hexadecimal is:

2A 2B 30 30 30 33 2E 36 0F

Note:

When the measured angle is out of the range, it will display: 为 2A 2B 30 38 38 38 2E 38 0F.

VI. User Commands (the following commands is hexadecimal) :

1. 0x1A 0x0C XX 0x0D — Set address of the sensor's axes. Successful setting will get a return value of 0x2A 0x0C XX 0x0F, XX represents the sensor's axes' address, which can be valued from 0x01 to 0x20, factory default address is 0x01;
2. 0x1A 0x1C XX 0x0D — Set the current angle as zero position. Successful setting will get a return value of 0x2A 0x1C 0x0F, XX represents the sensor's axes' address;
3. 0x1A 0x0E NN 0x0D — Set filter parameter. NN can be valued 0x01(the fastest) /0x02/ 0x03 /0x04(the slowest). There is no return value after successfully set, and the sensor get into the ready state;
4. 0x1A 0x1E XX 0x0D — Read the tilt angle, XX represent the sensor's axes' address, and the return value can be referred to the digital output of the angle.

VII. Mounting Size and Attentions:

1. Appearance and Mounting Size

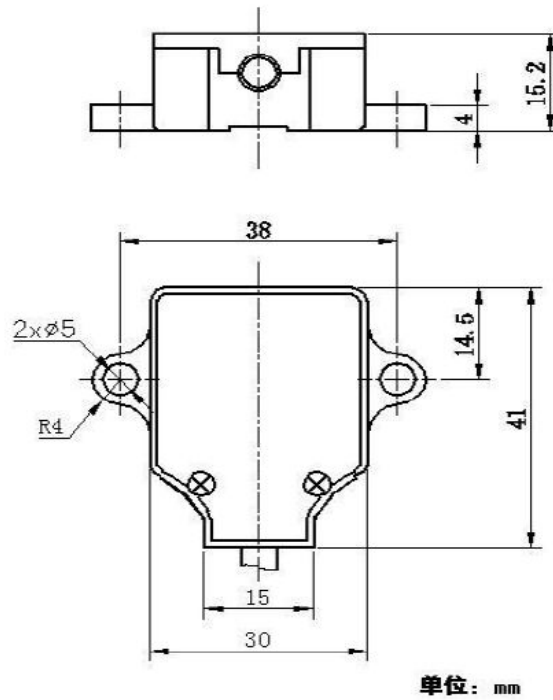

2. Wire connection (provided by customers)

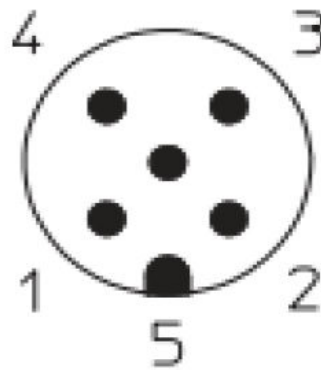

1	Schirm / shield
2	7V~12V
3	GND (0 V)
4	RS-485 A
5	RS-485 B

3. Wire connection (default parameter)

1 Red	7V~12V
2 Black	GND (0 V)

3 Blue	RS-485 A
4 Yellow	RS-485 B

4. PCB Size and Wire definition

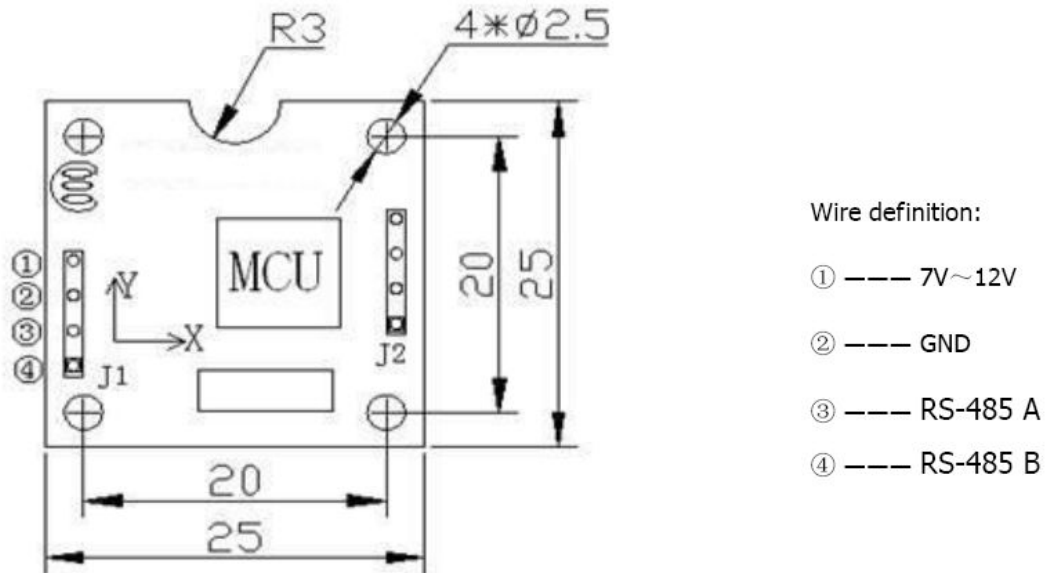

4. Attentions when mount the sensor

①. The sensor should be mounted vertically. When the lead cable is toward to right, sensor is in the zero position. Rotate the sensor in clockwise, the angle will increase.

②. Incorrect installation methods will lead to the measurement error. In order to minimize the mount error, please make sure the sensor perpendicular with the horizontal plane.

VIII. Order Information: Part# ZCT100AL-485-BUS: Aluminum alloy housing

ZCT100AN-485-BUS: PCB Mouldle

Specifications subject to change without notice!